

Compact Illuminator Range

Models covered by this manual:

UFO 70/150 CG-A Glass, White Light - 120V

UFO 70/150 CP-A Plastic, White Light - 120V

UFO 70/150 CGC-A Glass, Color Wheel (continuous) - 120V

UFO 70/150 CPC-A Plastic, Color Wheel (continuous) - 120V

UFO 70/150 CGS-A Glass, Color Wheel (switch on box) - 120V

UFO 70/150 CPS-A Plastic, Color Wheel (switch on box) - 120V

UFO 70/150 CGCF-A Glass, Color Wheel (separate feed) - 120V

UFO 70/150 CPCF-A Plastic, Color Wheel (separate feed) - 120V

INTRODUCTION

Thank you for purchasing this UFO Illuminator.

Please read these instructions fully before connecting your unit to the electrical supply, and keep them for future reference.

The UFO Compact illuminators are a range of low profile illuminators which use either 70W or 150W metal halide discharge lamps to give much greater brightness than those powered by halogen lamps.

These models have a fast re-lamping feature (the lamp is mounted on a pull out hatch at the rear) and can be fitted with a combination of color, twinkle or dimmer wheels for providing lighting effects.

IMPORTANT

THIS PRODUCT MUST BE INSTALLED IN ACCORDANCE WITH THE APPLICABLE INSTALLATION CODE BY A PERSON FAMILIAR WITH THE CONSTRUCTION AND OPERATION OF THE PRODUCT AND THE HAZARDS INVOLVED



Do not operate without complete lamp enclosure in place or if lens is damaged.

KEEP HARNESS IN PLACE WHEN IN OPERATION.

CAUTION: Hot surface. Keep away from curtains and other combustible materials.

WARNING: RISK OF FIRE/INJURY TO PERSONS. Keep away from combustibles. Unplug to change lamp. Do not touch lamp.

WARNING: RISK OF FIRE. Do not place lamp where the overhead surface is closer than 0.2m (8") to the illuminator.

IMPORTANT SAFETY INFORMATION

INSTRUCTIONS PERTAINING TO A RISK OF FIRE, ELECTRIC SHOCK OR INJURY TO PERSONS

IMPORTANT SAFETY INSTRUCTIONS

Lighted Lamp is HOT:

WARNING – To reduce the risk of FIRE, ELECTRIC SHOCK OR INJURY TO PERSONS:

1. Unplug and allow to cool before replacing lamp.
2. Lamp gets HOT quickly! Only contact plug when turning on.
3. Do not touch hot lens, guard, or enclosure.
4. Do not remain in light if skin feels warm.
5. Do not look directly at lighted lamp.
6. Keep lamp away from materials that may burn.
7. Use only with a 150W or smaller lamp.
8. Do not touch the lamp at any time. Use a soft cloth. Oil from skin may damage lamp.
9. Do not operate product with missing or damaged guard, lamp containment barrier, lens or fiber-optic harness.

SAVE THESE INSTRUCTIONS

- Always disconnect the unit from the power supply before opening or attempting to perform any work on it.
- **UNIT MAY GET HOT** - always allow unit to cool down before handling or moving it.
- Do not touch or attempt to remove the lamp while it is hot.
- Ensure that the power supply is correct for the unit before powering it up.
- Always ensure that the unit is properly **GROUND**ED.
- Do not expose the unit to rain or moisture.
- Keep away from all combustible materials.
- Never attempt to tamper with the wiring or other internal components.
- Keep the unit away from gas, oil and any other flammable or explosive materials.
- Indoor use only.

LIGHTSOURCE LAYOUT

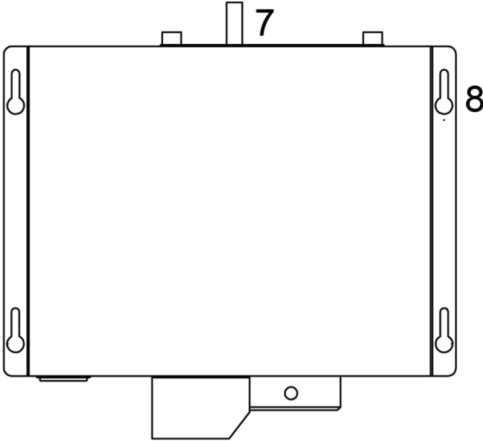
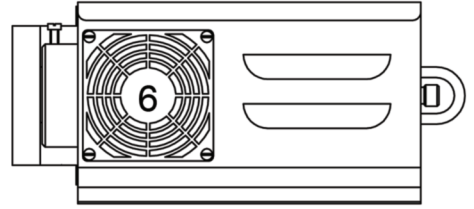
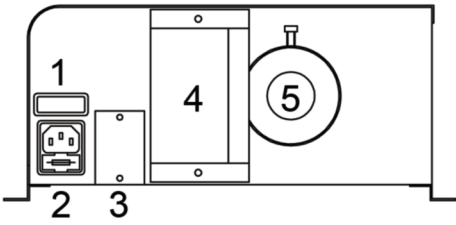

Item	Description
1	Power LED
2	Mains input socket & fuse holder
3	Blanking plate, color wheel switch or color wheel mains input and fuse holder - depends on specification
4	Motor cover (decorative units only)
5	Fiber port connector
6	Cooling fan
7	Lamp access hatch
8	Securing holes (keyhole slots)

INSTALLATION GUIDE

In order for the Compact illuminator to function safely and efficiently it must be installed according to this user manual. Please read all sections thoroughly before switching on the illuminator.

POWER SUPPLY REQUIREMENTS

Before plugging in the unit, please make sure that the supply is correct. Failure to do so could cause the unit to malfunction. The unit requires a 120VAC, 60Hz supply and it **MUST BE GROUNDED**. The illuminator units are provided with a cordset fitted with a standard 3-pin plug.

POSITIONING THE UNIT

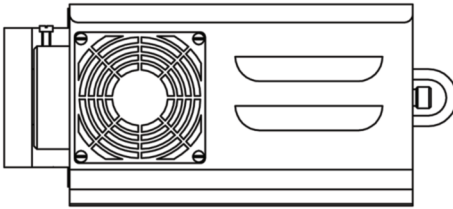

Standard horizontal mounting
(on shelf / table)

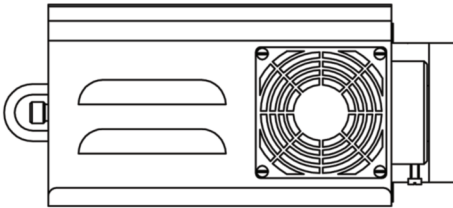

Upside down mounting
(fixed to underside of shelf)

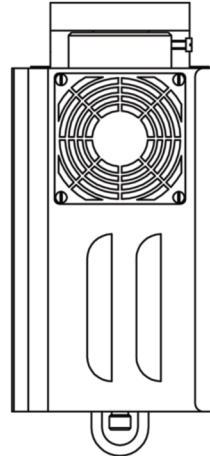

Vertical mounting
(fixed to wall)

The illuminator can be mounted horizontally, vertically or upside-down on any flat surface. Keyhole slots are provided on the base of the unit to allow for securing to a surface. The illuminator is only suitable for use in a dry area.

If the unit is being mounted at a higher than the ground level, block access below the work area before installing.

Verify that any screws or bolts can safely bear the weight of the illuminator.

INSTALLATION GUIDE (Continued)

Verify that the supporting structure can safely bear the weight of all installed units, cables and any other equipment. The minimum thickness of the mounting surface must be no less than 19mm.

For horizontal mounting, it is recommended that the illuminator is secured to a solid surface using 4 x M4 or M5 screws or bolts and the keyhole slots. This is particularly important if the illuminator location is not at ground floor level.

To mount the illuminator vertically, first securely install 4 x M4 or M5 screws or bolts at the required distances so that they will line up with the keyhole slots. The illuminator can then be mounted onto them and slid into position. The bolts or screws **MUST** then be fully tightened.

To mount the illuminator under a surface, first securely install 4 x M4 or M5 screws or bolts at the required distances so that they will line up with the keyhole slots. The illuminator can then be mounted onto them and slid into position. The bolts or screws **MUST** then be fully tightened.

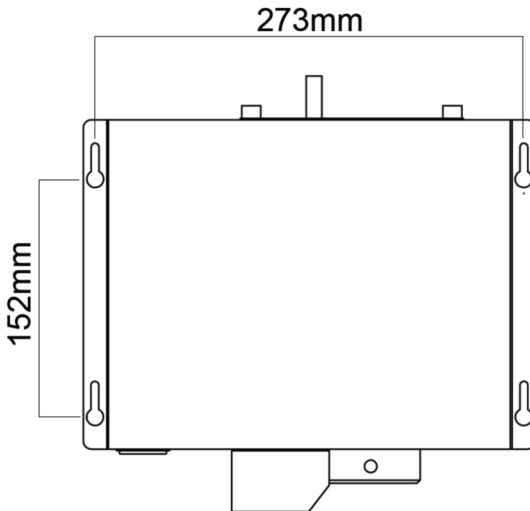

CLEARANCE / VENTILATION

It is recommended that a gap of 200mm (8") or more is left around the unit. This is to allow air to circulate and prevent overheating. The location must have free ventilation.

INSTALLATION GUIDE (Continued)

CONNECTION

There are 2 main connections required - the fiber port and the line power supply. On units with a separate electrical feed to the color wheel, 2 mains power connectors are required. Connect and secure the fiber optic connector to the fiber port before connecting the electrical supply. Never run the illuminator with the fiber connector unplugged.

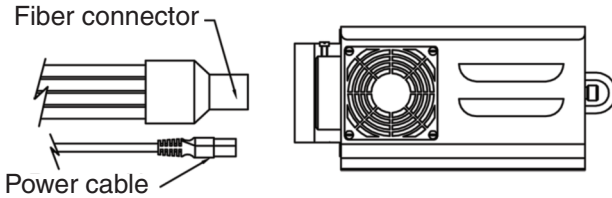

OPERATION

Switch on the power to the illuminator and it will start up automatically. Light will be output from the port connector and throughout the fiber harness. On models with a switch controlled effects wheel or a separate electrical feed to the effects wheel, the rotation of the effects wheel can be independently switched on or off. On other models the effects wheel will rotate continuously.

If no light is produced, please consult the TROUBLESHOOTING section in this manual

MAINTENANCE

LAMP REPLACEMENT

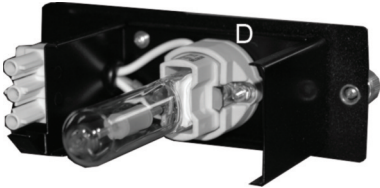
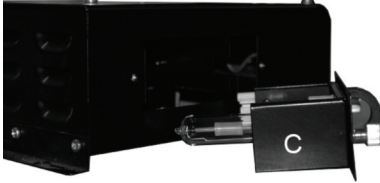
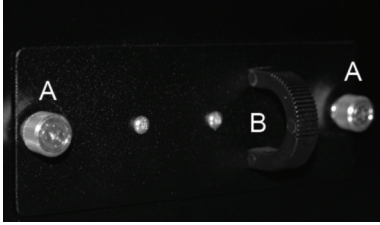

- 1) Unplug unit from electrical supply and allow to cool.
- 2) On the rear of the unit, unscrew the two knurled securing nuts (A) which hold the lamp holder in position.
- 3) Use the handle (B) to withdraw the lamp holder (C) from the illuminator.
- 4) Unplug the old lamp from its ceramic holder.
- 5) Plug the new lamp into the holder, making sure that you use a bulb of the same specification as to that which was removed. Also make sure not to touch the glass part of the lamp.
- 6) Slide the lamp holder plate back into position and tighten the two retaining nuts.

FUSE REPLACEMENT



- 1) Unplug unit from electrical supply and allow to cool.
- 2) The fuse is located in a drawer under the mains input connector.
- 3) Open the fuse drawer.
- 4) Withdraw fuse from its holder
- 5) Replace with identically specified fuse - see specification table in this manual.
- 6) Close the fuse drawer and power up the light source.

MAINTENANCE (Continued)

CLEANING THE UNIT

Disconnect unit from power supply and allow to cool before attempting any cleaning of the unit.

The body of the unit can be cleaned with a soft, damp cloth - do not use any abrasives on the unit.

The fans and vents should be kept clear by periodically blowing them out with compressed air.

Non-abrasive glass cleaner can be used to clean the glass lens inside the unit.

Please note that a record of all maintenance MUST be kept in the table below, indicating what maintenance was undertaken and when.

Date	Maintenance Undertaken

TROUBLESHOOTING

Problem	Probable cause(s)	Remedy
Unit is completely dead - Lamp and LED power indicator are not illuminated	Main fuse blown	Check and replace fuse.
	No power to unit	Check that power is switched on and power supply is plugged in.
LED power indicator & fan are on, but no light is output	Lamp blown	Replace lamp
	Thermal switch activated	Allow unit to cool for 5 to 10 minutes and investigate reason for overheating
	Lamp wires are not connected	Check plug connection - ensure lamp is properly seated in its holder and the pins are fully mated
Poor light output	Lamp needs replacing	Replace lamp
	Unit needs cleaning	Clean glass lens
	Incorrect power supply	Ensure power supply is 120VAC 60Hz
	Fiber port connector not plugged in correctly	Ensure fiber port connector is plugged in correctly, and that the screw is tightened up properly
Lamp going on & off randomly	Unit is overheating	Allow unit to cool for 5 to 10 minutes and investigate reason for overheating

TECHNICAL SPECIFICATIONS

Description	70W White Light	70W Decorative	150W White Light	150W Decorative
Port connector size	30mm diameter	30mm diameter	30mm diameter	30mm diameter
Fiber type	Glass / PMMA	Glass / PMMA	Glass / PMMA	Glass / PMMA
Supply voltage	120VAC 60Hz	120VAC 60Hz	120VAC 60Hz	120VAC 60Hz
Lamp power	70W	70W	150W	150W
Input power	120VA @ 120VAC	120VA @ 120VAC	180VA @ 120VAC	180VA @ 120VAC
Start up current	0.39A @ 120VAC	0.39A @ 120VAC	0.7A @ 120VAC	0.7A @ 120VAC
Running current	0.73A @ 120VAC	0.73A @ 120VAC	1.5A @ 120VAC	1.5A @ 120VAC
Min. ambient temp.	-20°C	-20°C	-20°C	-20°C
Max. ambient temp.	40°C	40°C	40°C	40°C
Thermal protection	Thermal switch	Thermal switch	Thermal switch	Thermal switch
Ballast type	Electronic	Electronic	Electronic	Electronic
Fan type (glass fiber)	Papst 8830N	Papst 8830N	Papst 8830N	Papst 8830N
Fan type (PMMA fiber)	Papst 8800N	Papst 8800N	Papst 8800N	Papst 8800N
Power cord	IEC mains cable	IEC mains cable	IEC mains cable	IEC mains cable
Main fuse	4 Amp	4 Amp	4 Amp	4 Amp
Secondary fuse for color wheel (separate feed models only)	1 Amp	1 Amp	1 Amp	1 Amp
Lamp type	Metal halide	Metal halide	Metal halide	Metal halide
Lamp model	Philips CDM-T or CDM	Philips CDM-T or CDM	Philips CDM-SA/T or CDM	Philips CDM-SA/T or CDM
Lamp life	c. 9000h	c. 9000h	c. 6000h	c. 6000h
Lamp color temp.	4200K (CDM-T) 3000K (CDM)	4200K (CDM-T) 3000K (CDM)	4200K (SA/T) 3000K (CDM)	4200K (SA/T) 3000K (CDM)
Lamp CRI	96 (CDM-T) 85 (CDM)	96 (CDM-T) 85 (CDM)	96 (SA/T) 85 (CDM)	96 (SA/T) 85 (CDM)
Operating environment	Indoor / dry	Indoor / dry	Indoor / dry	Indoor / dry
Protection rating	IP20	IP20	IP20	IP20
Material	Sheet steel	Sheet steel	Sheet steel	Sheet steel
Color	Black	Black	Black	Black
Size	288x250x100 mm	288x277x129 mm	288x250x100 mm	288x277x129 mm
Weight	3.2kg	3.5kg	3.2kg	3.5kg

Universal Fiber Optics

Home Place, Coldstream, TD12 4DT, United Kingdom
Tel: +44 (0)1890 883416 | Fax: +44 (0)1890 883062
www.fibreopticlighting.com | info@fibreopticlighting.com